

HC3 instruction sheet

For use on: Suzuki

Components supplied in your Piranha hub assembly:

Center Hub	CHHC
Rear Cap	RCOC
Additional	SSWA spacer
Additional	RSSC spacer
Additional	Grease
Additional	Suzuki bulletin

Your original hardware needed:

Stock thrustwasher	X
Stock flatwasher	X
Stock prop nut	X
Stock cotter pin	X

Installation procedure: (also see diagram below)

1. Remove your old prop and hardware
2. Thoroughly clean, then lube your driveshaft with supplied grease
3. Reinstall your original thrustwasher
4. Install your assembled Piranha prop
5. Install the SSWA spacer supplied, followed by the RSSC spacer into the rear cap of the propeller
6. Reinstall your original flatwasher
7. Reinstall your original prop nut and tighten to approximately 20 ft-lbs of torque
8. Reinstall your cotter pin to retain the prop nut

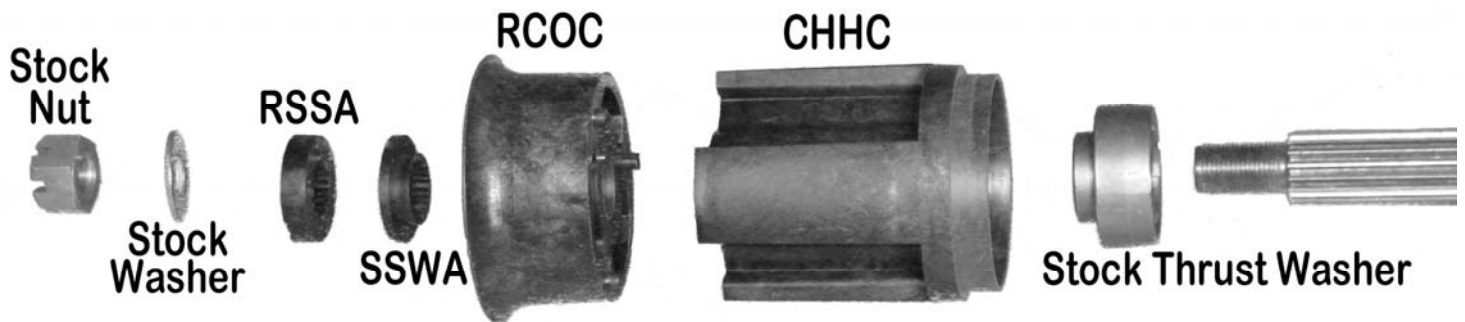

YOUR PROPELLER SHOULD ROTATE FREELY. IF YOUR PROPELLER DOES NOT ROTATE FREELY, CALL THE FACTORY AT 800-235-7767

Gearhead fitcheck: Dimensions of a properly fitting hub are shown here. If you have any difficulty installing your prop, please take these measurements prior to calling the factory.

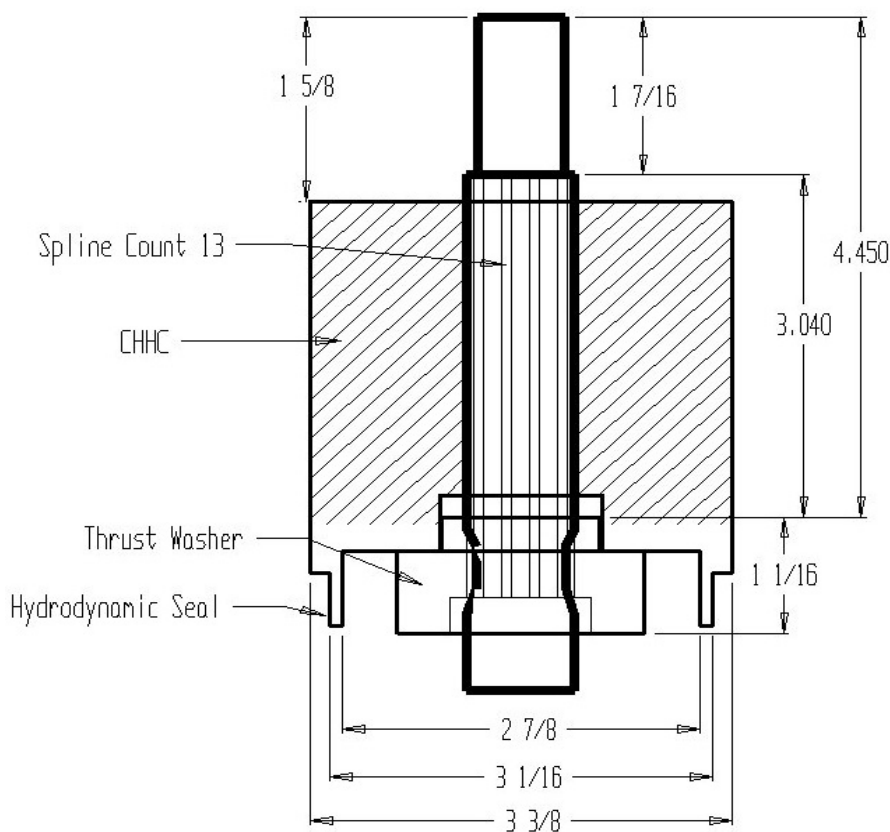

Assembling the propeller:

1. Insert the blades into the blade sockets. The blades are tapered, so if they do not slide in easily, try turning them over. They should slide in the majority of the way. Tap them until they are flush with the hub.
2. Press the rear cap on to hold the blades. Be sure to align the pins on the cap with the holes on the hub, this ensures the exhaust ports are open.



FACTORY POLICIES:

Exchanges: If your Piranha blades do not perform within the manufacturer recommended Wide Open Throttle rev range, or you would like to adjust your performance contact your local dealer or the Piranha factory. Provided the blades are in like new condition they may be exchanged for a different pitch
Average RPM ranges for applications using the SC3 hub:

Suzuki Outboard

2 stroke: 5200-5800

4 stroke: 5500-6500

Refunds: If, for some reason the Piranha Prop does not perform on your application, Piranha will issue a refund, less shipping charges, for any undamaged items returned within 30 days of purchase

Lifetime center hub warrantees: If your center hub sustains any damage, contact your local dealer, or the factory and exchange it for a new center hub

Piranha Propellers
3681 Sacramento Dr, Ste D
San Luis Obispo, CA 93401
1-800-235-7767
www.piranha.com